

Pieter van der Wolf

Sk' abekel' U.

:

.

.

MIO 1

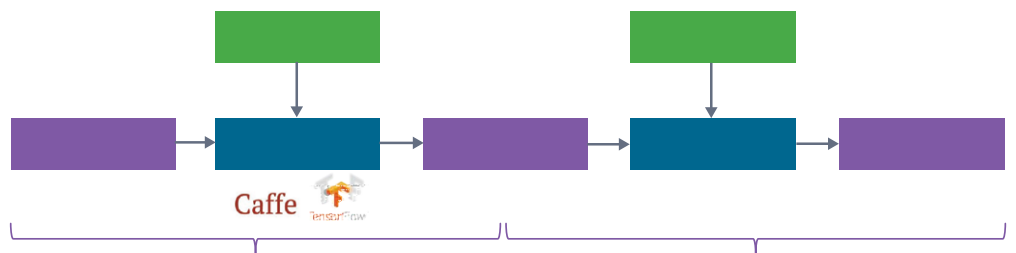

1

CSXXW TW ea d' ai



(CNN)

3

(M23)

(2, 3)

A24-A26 A34-A36 A44-A46

M24

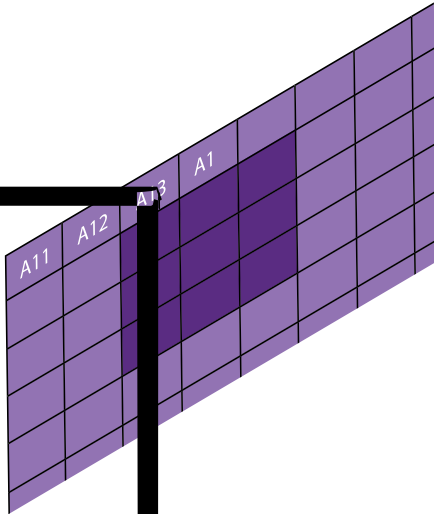

$$\begin{aligned} M23 = & W11 \times A23 + W12 \times A24 + W13 \times A25 \\ & + W21 \times A33 + W22 \times A34 + W23 \times A35 \\ & + W31 \times A43 + W32 \times A44 + W33 \times A45 \end{aligned}$$

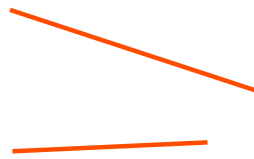

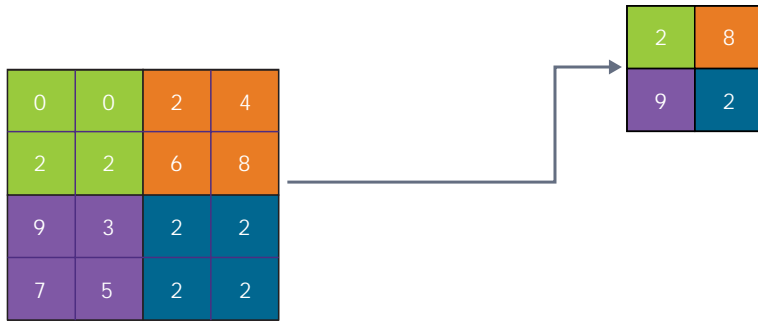

/

32 DSP ARC EM9D

MAC

(MAC)

5

ARC EM9D

MAC

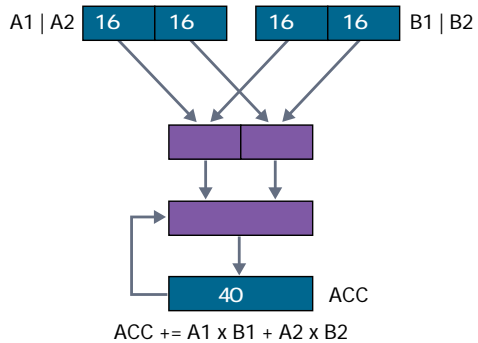

5 ARC EM9D

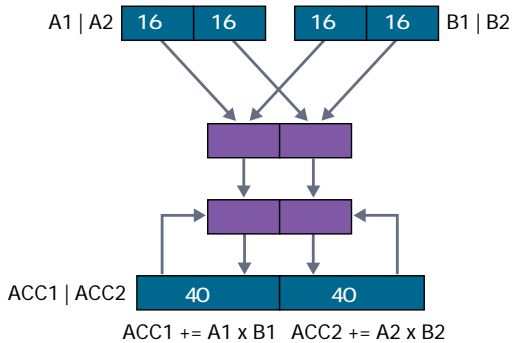

MAC

MAC

2j 16

DMAC

MAC

A1 A2

DMAC

B1 B2

ARC EM9D

32

8

5

HMAC

-MAC

MAC

B1 B2

A1 A2

MAC

MAC

ARC EM9D

JK

JK

6

AGG

AGG

(AGG)

AGG

AGG



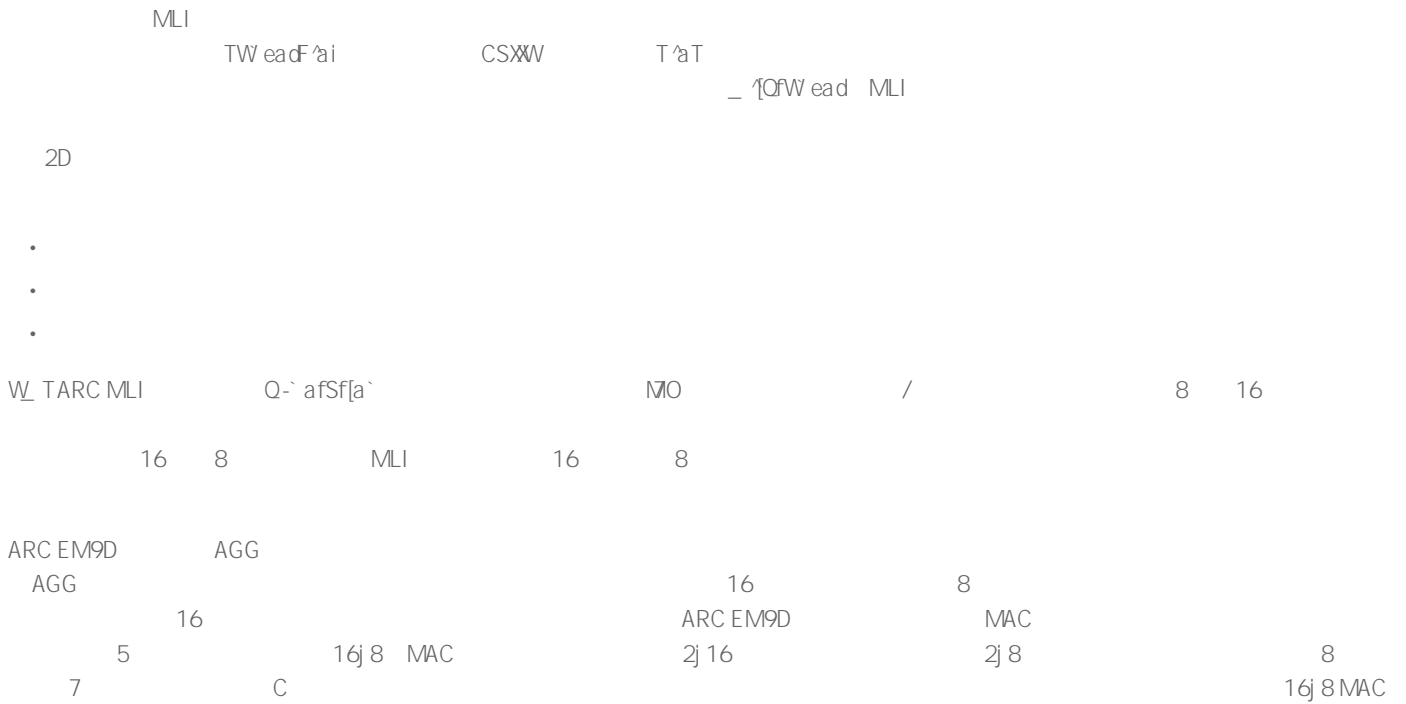

```

; AGU 0 is used for input data. AGU 1 is used for weights
; setup AGU 0 for loading next 2x16-bit vector
; setup AGU 1 for loading next 2x8-bit into lower bytes of 32-bit word

A B 0, %agu_u0, %agu_u1 ; DMAC + 2 loads + 2 pointer updates
:

```

7 MLI C 16 8



```

; AGU 0 and AGU 1 are used for input data (one data pointer with two modifiers)
; AGU 2 is used for weights
; setup AGU 0 for loading next two 16-bit input values
; setup AGU 1 for loading two 16-bit input values at next row of input data
; setup AGU 2 for loading next 8-bit value with sign extension & replication
...
A 2 0, %agu_u0, %agu_u2 ; VMAC + 2 loads + sign ext + repl + 2 pointer updates
A 2 0, %agu_u0, %agu_u2 ; VMAC + 2 loads + sign ext + repl + 2 pointer updates
A 2 0, %agu_u1, %agu_u2 ; VMAC + 2 loads + sign ext + repl + 2 pointer updates
:

```

8 MLI C 16 8 2D

AGG

2D

- CS~~W~~

([ 2Ua )  
AGG

ARC EM9D

W\_ TARC MLI

W\_ TARC MLI

3j 3

1

TW ea dF 'a i

SAME

`ml i_krn_depthwise_conv2d_chw_fx8w16d_k3x3_str1_krnpad(...)`

W\_ TARC MLI

C++

(i dSbbWd)

W\_ TARC MLI

ARC

EM9D

MWSI SdW

C/C++

DSP

ARC EM9D

W\_ TARC MLI

ARC

W\_ TARC MLI



```

mli_krn_permute_fx8(&input, &permute_hwc2chw_cfg, &ir_Y);

ir_X.el_params.fx.frac_bits = CONV1_OUT_FRAQ;
mli_krn_conv2d_chw_fx8_k5x5_str1_krnpad(&ir_Y, &L1_conv_wt, &L1_conv_b, &conv_cfg, &ir_X);
mli_krn_maxpool_chw_fx8_k3x3(&ir_X, &pool_cfg, &ir_Y);

ir_X.el_params.fx.frac_bits = CONV2_OUT_FRAQ;
mli_krn_conv2d_chw_fx8_k5x5_str1_krnpad(&ir_Y, &L2_conv_wt, &L2_conv_b, &conv_cfg, &ir_X);
mli_krn_avepool_chw_fx8_k3x3_krnpad(&ir_X, &pool_cfg, &ir_Y);

ir_X.el_params.fx.frac_bits = CONV3_OUT_FRAQ;
mli_krn_conv2d_chw_fx8_k5x5_str1_krnpad(&ir_Y, &L3_conv_wt, &L3_conv_b, &conv_cfg, &ir_X);
mli_krn_avepool_chw_fx8_k3x3_krnpad(&ir_X, &pool_cfg, &ir_Y);

ir_X.el_params.fx.frac_bits = FC4_OUT_FRAQ;
mli_krn_fully_connected_fx8(&ir_Y, &L4_fc_wt, &L4_fc_b, &ir_X);

ir_Y.el_params.fx.frac_bits = FC5_OUT_FRAQ;
mli_krn_fully_connected_fx8(&ir_X, &L5_fc_wt, &L5_fc_b, &ir_Y);
mli_krn_softmax_fx8(&ir_Y, &output);

```

10 CIFAR-10

MLI

10

(bVd\_gfV)  
[dJ [dK

RGB

W\_TARC MLI  
CHI

W\_TARC MLI

CIFAR-10CNN

MIOO

EM9D / ARC  
 JK DSP ARC EM9D MAC  
 W\_ TARC MLI ARC EM9D / CIFAR-10  
 Sk` abeke

## References

- [1] Samuel, Arthur (1959). "Some Studies in Machine Learning Using the Game of Checkers". IBM Journal of Research and Development. 3 (3): 210–229.
- [2] C. Szegedy, W. Liu, Y. Jia, P. Sermanet, S. Reed, D. Anguelov, D. Erhan, V. Vanhoucke, and A. Rabinovich. "Going deeper with convolutions". In Proceedings of the IEEE Conference on Computer Vision and Pattern Recognition, pages 1–9, 2015.
- [3] [www.synopsys.com/ev](http://www.synopsys.com/ev)
- [4] Benoit Jacob, Skirmantas Kligys, Bo Chen, Menglong Zhu, Matthew Tang, Andrew Howard, Hartwig Adam, and Dmitry Kalenichenko. "Quantization and training of neural networks for efficient integer-arithmetic-only inference". arXiv preprint arXiv:1712.05877, 2017.
- [5] <https://embarc.org/>
- [6] Dario Amodei, Sundaram Ananthanarayanan, Rishita Anubhai, Jingliang Bai, Eric Battenberg, Carl Case, Jared Casper, Bryan Catanzaro, Qiang Cheng, Guoliang Chen, et al., "Deep speech 2: End-to-end speech recognition in english and mandarin", in International Conference on Machine Learning, 2016, pp. 173–182.
- [7] [https://en.wikipedia.org/wiki/Q\\_\(number\\_format\)](https://en.wikipedia.org/wiki/Q_(number_format))
- [8] Alex Krizhevsky. "Learning Multiple Layers of Features from Tiny Images." 2009.
- [9]

---

---