

Overview

The Synopsys SLM Path Margin Monitor (PMM) solution consists of multiple PMM units, a PMM controller, and associated software and EDA automation. PMM IP is a building block for the PMM solution which is also supported by an automated implementation flow from Synopsys. Path selection logic, RTL configuration and generation, connecting to functional and/or test paths, synthesis, implementation, timing validation and path qualification are the key functions addressed by the EDA automation provided. Associated software allows the data generated from the PMM solution to be effectively analyzed and precise decisions made based on those insights.

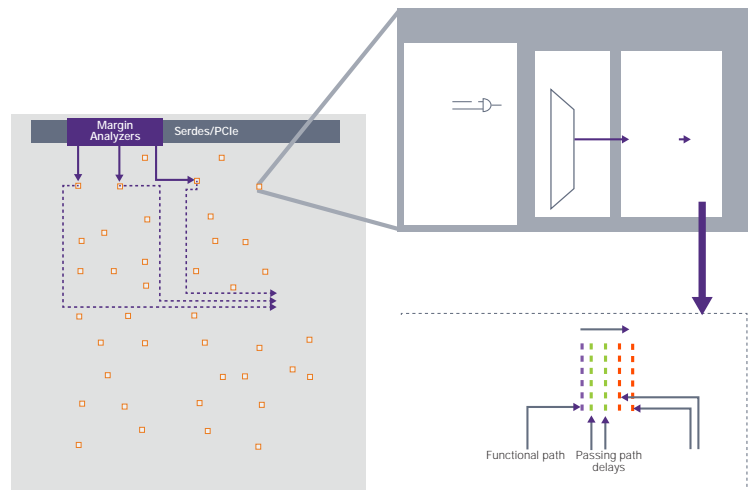

Path Margin Monitor Controller

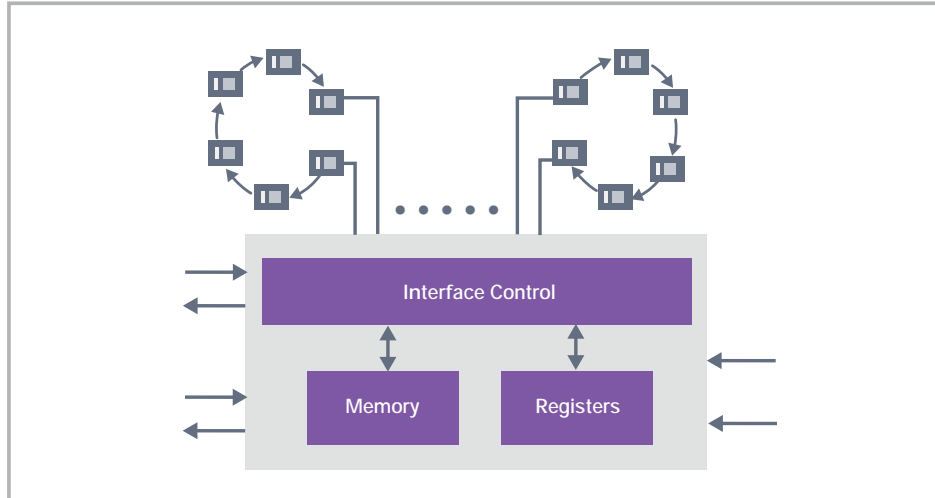

Key Benefits

- Provides visibility of silicon structural health
- Real time reporting for analytics
- Monitor test or functional paths throughout silicon lifecycle
- Optimize silicon performance based on actual margins available

Complete Design Flow

